

Vacuum gripping systems with foam / FCG

Power&Light 400x300 medium pitch with self-closing valves

FCG-400-0300-F25-R10-P30-VA

- The FCG-400 series of vacuum gripping systems, in the version with foam, is a modular and versatile solution for handling a variety of products of different sizes, shapes and porosity
- Ideal mainly for palletising cardboard boxes, interlayers and pallets
- Power&light version with light carbon body and high suction flow rate
- Integrated energy-efficient multi-stage EJ-LARGE-HF-3 cartridges
- Central vacuum port for connection to external vacuum source (blower, electric pump)
- Self-closing valves permit use with a smaller vacuum pump, ensuring a high vacuum level even if most of the surface of the gripper is not covered
- Additional vacuum sensing ports to monitor the vacuum level during gripping

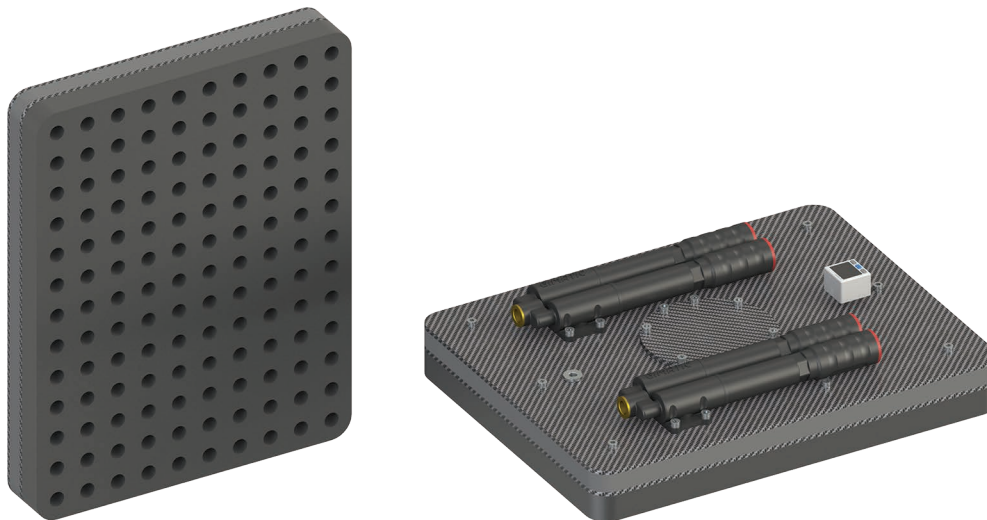

Technical features

Max feed pressure	0.6 MPa
Temperature range	0 ÷ +50 °C
Weight	4.5 kg
Material	CF, EPDM, NBR, PA12
Noise level	70 dB

Suction flow rate

Model	Feed pressure [MPa]	Air consumption [l/s]	Suction flow rate [l/s] at different vacuum levels								Max vacuum [kPa]
			0	-10	-20	-30	-40	-50	-60	-70	
FCG-400-0300-F25-R10-P30-VA-EJL4	0.6	6.8	23.6	14	10	6.8	3.56	2.48	2.04	1.24	-73

Gripping force

Model	Gripping force [N] at different vacuum levels				
	-30 kPa	-40 kPa	-50 kPa	-60 kPa	-70 kPa
FCG-400-0300-F25	1015	1300	1650	2000	2300

Theoretical gripping force on flat surface with fully covered gripping surface, excluding the factor of safety
Standard 25 mm thickness of foam

Identification codes

Drawing	Alphanumeric code	Description	Order code
A	FCG-400-0300-F25-R10-P30-VA-EJL4	Vacuum gripping system with 25 mm thick foam, 400x300 mm, medium pitch, with integrated self-closing valves, and integrated vacuum generator	373400001
B	FCG-400-0300-F25-R10-P30-VA-G1	Vacuum gripping system with 25 mm thick foam, 400x300 mm, medium pitch, with integrated self-closing valves, and central G1" vacuum connection	373400002

A

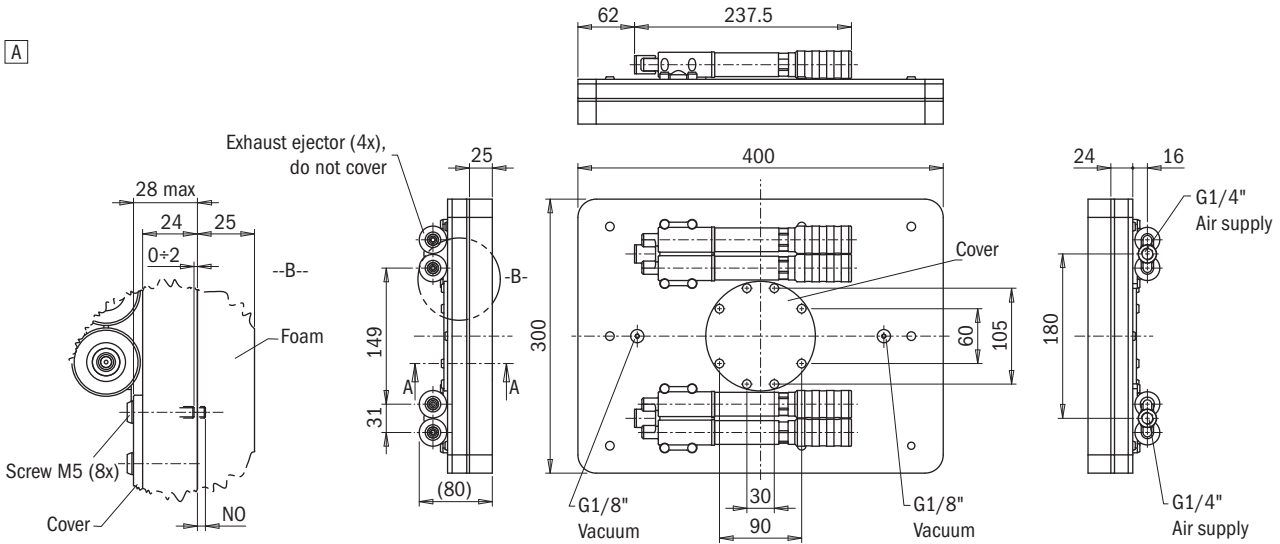

Reference dimensions for interface assembly.
Do not exceed the recommended measures

B

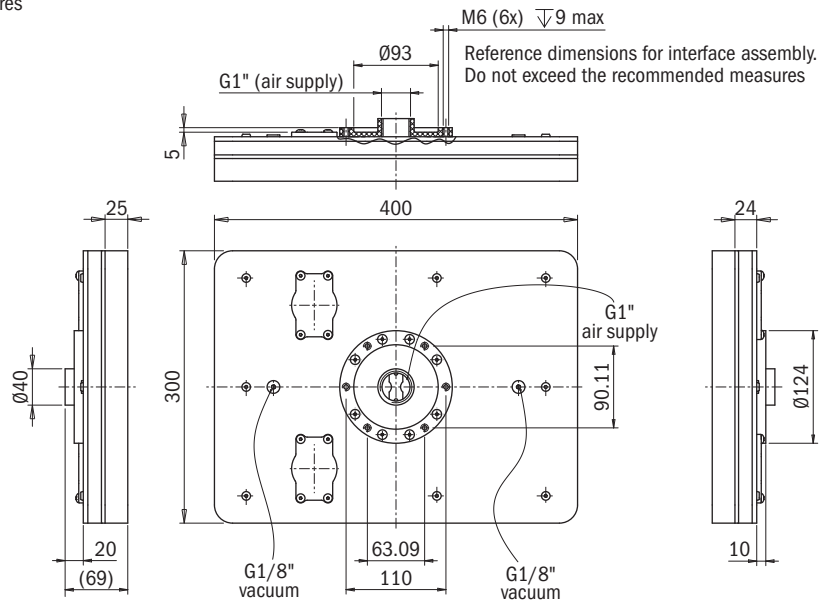

Reference dimensions for interface assembly.
Do not exceed the recommended measures

Identification codes

Alphanumeric code	Spare parts	Order code
FCG-400-0300-F25-R12	Spare EPDM foam, 400x300 mm, 25 mm thick, medium pitch	373400300

