

**Sospensioni inox anti-rotazione per carichi elevati**

- Corpo, stelo, cuscinetto e molla in acciaio inossidabile.
- Guida a sfere per un'altissima capacità di carico.
- Gioco zero.
- Grasso alimentare FDA-H1.
- Pressione di utilizzo: -1 ÷ 8 bar.

**Non-rotative heavy duty stainless suspensions**

- Body, rod, bearing and spring in stainless steel.
- Ball bearing for a very high load capability.
- Zero backlash.
- FDA-H1 food-grade grease.
- Pressure range: -1 ÷ 8 bar.

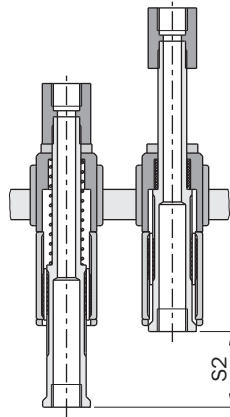
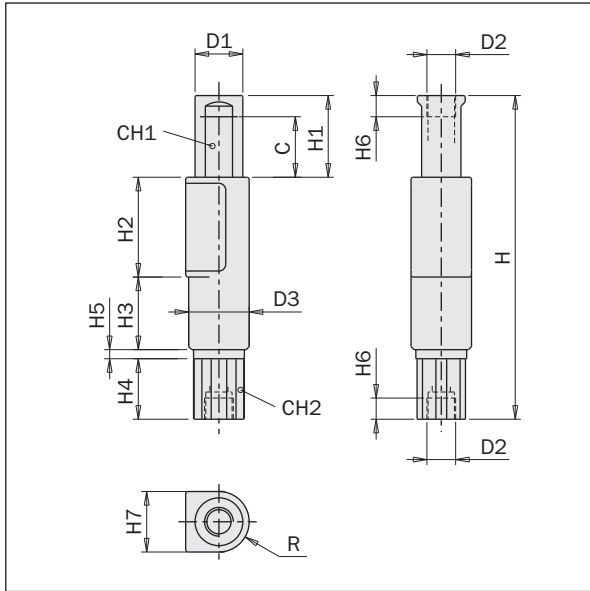

	WX1010F	WX1025F	WX1420F	WX1435F	WX2025F	WX2050F
H [mm]	63	100.5	99	137	107	169
H1 [mm]	11	26	25	40	27	52
H2 [mm]	23.5	35	31	43	33	50.5
H3 [mm]	12	23	21	32	24	43.5
H4 [mm]	15	15	20	20	20	20
H5 [mm]	10	10	14	14	20	20
H6 [mm]	6	6	7	7	7	7
H7 [mm]	8	8	10	10	11	11
D1 [mm]	Ø7.8	Ø7.8	Ø11.8	Ø11.8	Ø15.8	Ø15.8
D2	M5	M5	G1/8"	G1/8"	G1/8"	G1/8"
D3 [mm]	Ø10	Ø10	Ø14	Ø14	Ø20	Ø20
CH1 [mm]	6	6	10.5	10.5	13	13
CH2 [mm]	8	8	12	12	16	16
C [mm]	10	25	20	35	25	50
R [mm]	5	5	7	7	10	10
S2 [mm]	10	25	20	35	25	50
d [mm]	0	0	0	0	0	0
K [N/mm]	0.194	0.0786	0.252	0.137	0.258	0.129
R1 [N]	1.548	1.533	3.65	4.325	4.388	4.452
R2 [N]	3.483	3.498	8.685	9.132	10.84	10.9
m [g]	30	45	80	110	150	235